



**COMMUNICATION
SIGNAL**

【 Specifications & Remarks 】

1. Communication Signal Specifications
2. Cable Connections (Communication Cable)
3. Kinds and Formats of Communication Signals
4. Communication Sequence
5. Details of Command Signal
6. Details of Data Signal
7. Details of Attached Data
8. Errors List

Specifications & Remarks

- 1). This material compiles the basic communication signal specifications for the models, AD-800, AD-820, FD-80, LS-80, LS-82, and PM-80 and also for the Takubo's products to be released in the future.
- 2). The objective of the specifications aims at interactive communication.
- 3). This material is opened to ease the connections with the PC and the Internet.
- 4). We are ready to examine the modification of the machine operating software if we are requested for the revision of the communication signal formats.
- 5). One of the serial ports can be applied for the bar-code reader. This change requires the modification of the control P.C. board.
- 6). RS232C cable (Reverse Interlink spec.) is used as the communication cable.
- 7). Contents:
 - a.Set the transmission I.D. to [00] when communicating with the device not specified in this material.
 - b.Reception I.D. will be Takubo's product
 - c.Use the device I.D. when communicating with two or more machines of the same model with the PC.
 - d.Operation I.D.
 - e.VER I.D. changes the version when the contents of data signal, etc. are altered.
- 8). Device I.D. is not utilized at present.
- 9). 3-D data is the communication data from PM-80.
- 10). Both-eye data is the communication data from FD-80.
- 11). One of the serial ports can be used to connect a bar-code reader.
- 12). An exclusive-use connector for the bar-code reader is furnished with models, AD-820, LS-82, and FD-80, as a standard feature.

1 .Communication Signal Specifications

(1) Transmission type	Start-stop synchronization
(2) Transmission rate	9600 bps
(3) Parity	None
(4) Stop bit length	2 bit
(5) Data length	8 bit
(6) Data code	ASCII data / HEX. data
(7) RTS / CTS	Treated by Hardware
(8) DSR / CDC / DTR	Not used. Short-circuited inside corresponding P.C. board.

RTS: Shows whether or not own machine can receive communication signal.

CTS: Shows data reception condition of mating machine. Own machine must not change signal.

2. Cable Connections (Communication Cable)

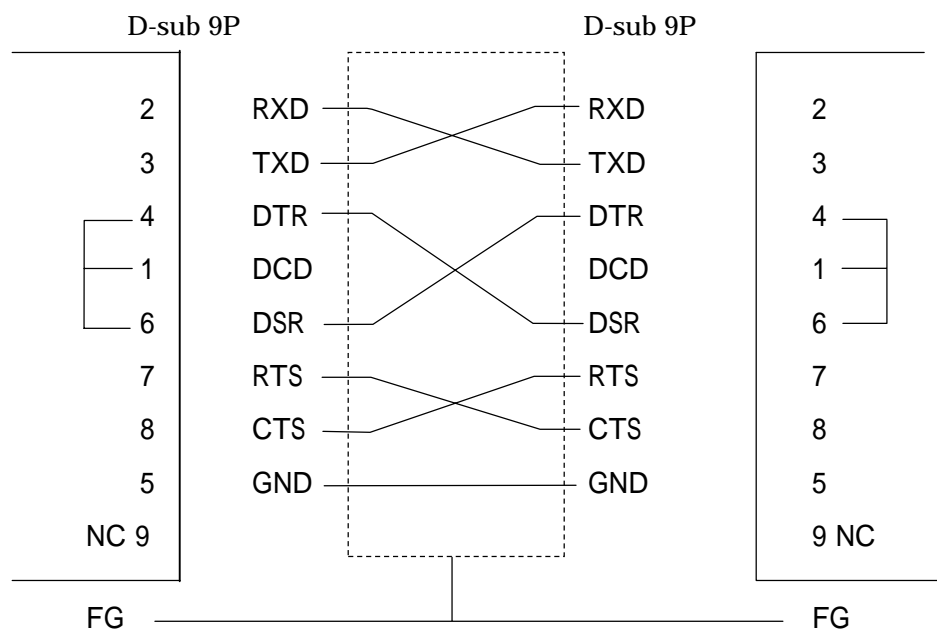

When connecting a bar-code reader, use the exclusive-use connector for the bar-code reader.

3. Kinds and Formats of Communication Signals

- (1) Kinds of communication signals
Command signal, Data signal
- (2) Kinds of control codes to be used
 - STX (02H) Text starts.
 - CR (0dH) Text ends.
 - EXT (03H) Return
- (3) Checksum
Attach checksum at the end of a data signal and a command signal.
Checksum includes STX and CR.
However, CR and EXT after the checksum are not included.
Content is the remainder of the sum of all the 1 byte data divided by 256.
(See "5. Details of Command Signal" for details.)
- (4) Transmission / Reception data
Data other than control codes are converted to the ASCII codes.
(HEX. and ASCII coexist with FD-80.)
- (5) Kinds of I.D. codes to be used
 - (a) Transmission I.D.
 - (00) Gnore
 - (05) AD-800, AD-820
 - (06) PM-80
 - (07) LS-80, LS-82
 - (08) FD-80
 - (10) PC (Personal Computer)
 - (98) Takubo exclusive communication
 - (b) Reception I.D.
 - (00) Ignore
 - (05) AD-800, AD-820
 - (06) PM-80
 - (07) LS-80, LS-82
 - (08) FD-80
 - (10) PC (Personal Computer)
 - (98) Takubo exclusive communication
 - (c) Device I.D.
 - (00) Ignore
 - (d) Operation I.D.
 - (00) Ignore
 - (01) Transmission possible confirm
 - (02) Transmission possible
 - (03) Transmission request
 - (04) Transmission start
 - (05) Bar-code transmission request
 - (50) Exclusive use by Takubo

- (e) VER I.D. (Data version flag)
- (00) Ignore
 - (03) 3-D data
 - (06) Both-eye data
 - (09) Exclusive use by Takubo
 - (10) E2ROM exclusive I.D. (Write data into machine) 2001/1
 - (50) Exclusive use by Takubo
 - (51)-(59) Takubo-Exclusive RAM I.D. (See supplementary explanation below.)
 - (99) Exclusive use by Takubo

Supplementary explanation for (51)-(59)

AD-800, AD-820	PM-80	LS-80, LS-82
51: Sensor - F value	51: E2DAT value	51: Communication value
52: Sensor - V value	52: Tracer - F value	52: Communication value
53: Sensor - Z value	53: Front-Rear value	53: Top-Bottom value
56: Communication value	54: Top-Bottom value	54: Attached data value
59: Memory value (E2ROM)	56: Lens value	
60: Top-Bottom value	59: Memory value (E2ROM)	

(f) Communication data body

(6) Command signal

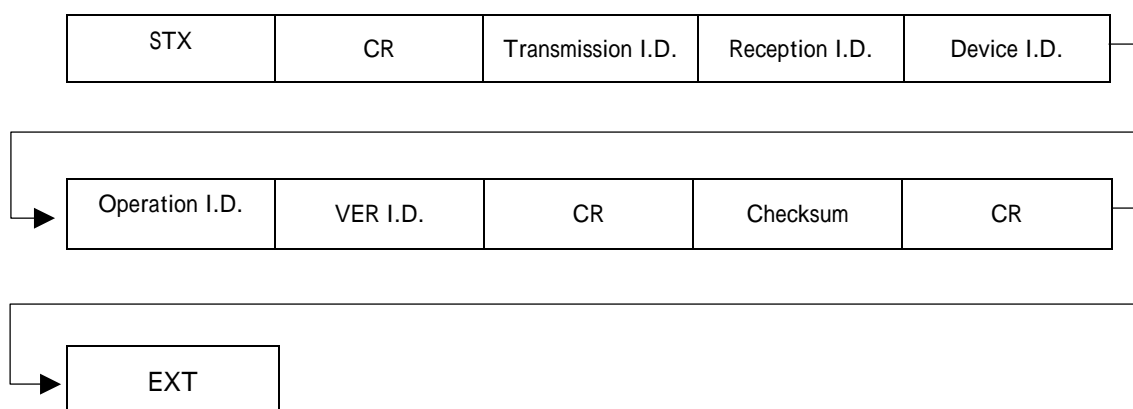

(7) Data signal

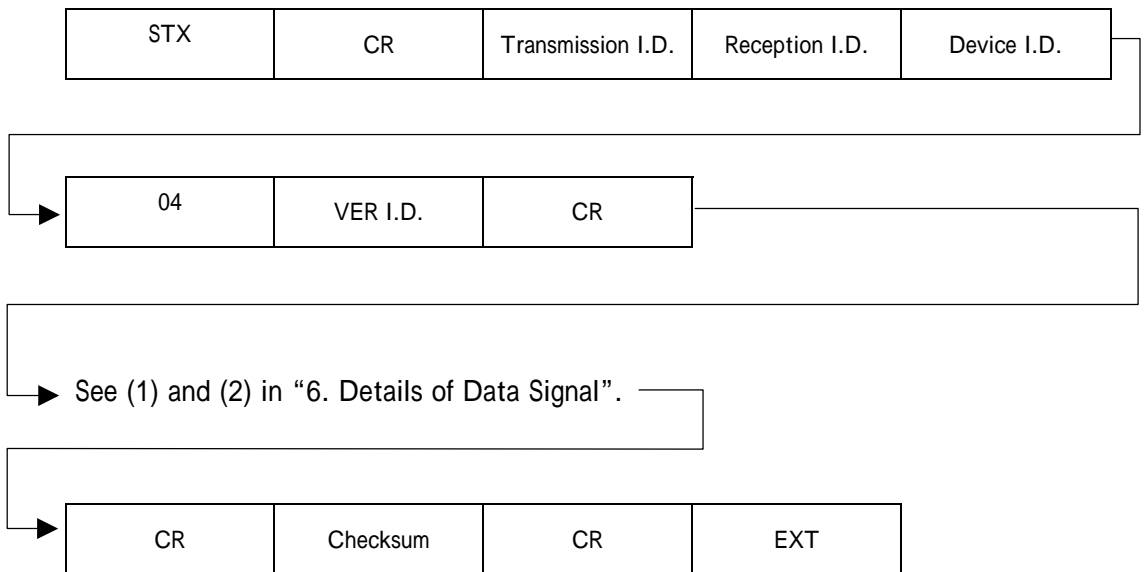

4. Communication Sequence

PM-80	Frame Scanner	-----	AD-800	Automatic Edger
			AD-820	Automatic Edger
PM-80	Frame Scanner	-----	LS-80	Lens Blocker
			LS-82	Lens Blocker
LS-80	Lens Blocker	-----	AD-800	Automatic Edger
LS-82	Lens Blocker		AD-820	Automatic Edger
FD-80	Frame Tracer	-----	LS-80	Lens Blocker
			LS-82	Lens Blocker
FD-80	Frame Tracer	-----	AD-800	Automatic Edger
			AD-820	Automatic Edger

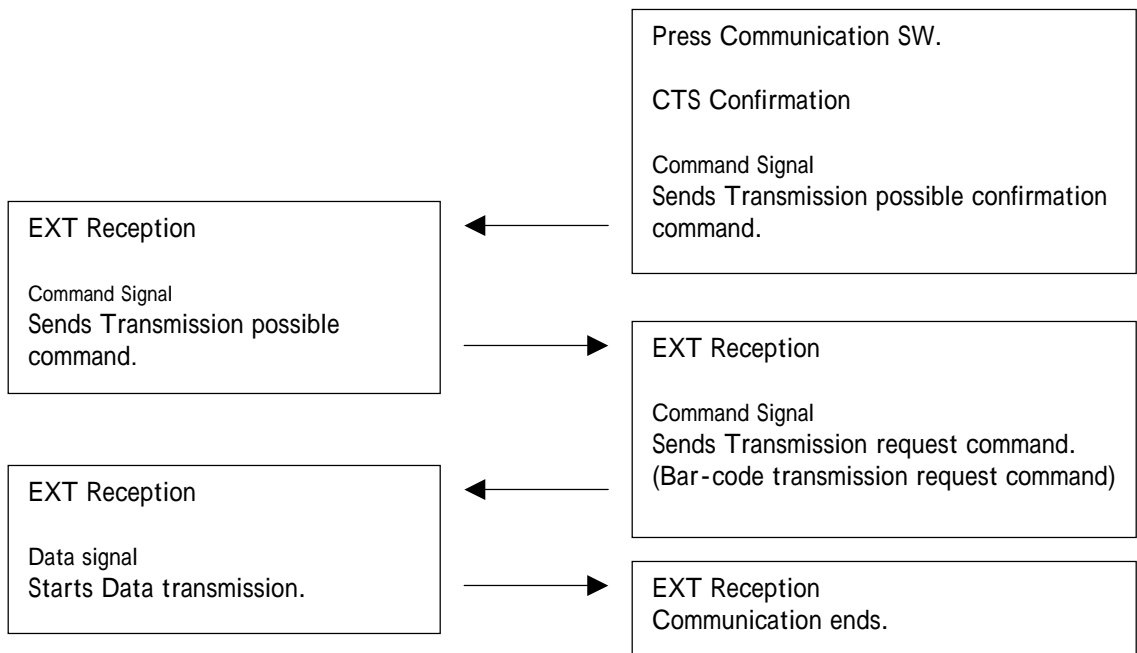

5. Details of Command Signal

(1) Transmission possible confirmation command

STX 02	CR 0d	05	06	00	01	03	CR 0d	SUM 0d
-----------	----------	----	----	----	----	----	----------	-----------

CR 0d	EXT 03
----------	-----------

Sends after converting to ASCII code

$SUM=02+0d+30+35+30+36+30+30+30+31+30+33+0d=20b$ (30,42ASCII conversion)

(2) Transmission possible command

STX 02	CR 0d	06	05	00	02	03	CR 0d	SUM
-----------	----------	----	----	----	----	----	----------	-----

CR 0d	EXT 03
----------	-----------

(3) Sending Transmission request command

STX 02	CR 0d	05	06	00	03	03	CR 0d	SUM
-----------	----------	----	----	----	----	----	----------	-----

CR 0d	EXT 03
----------	-----------

(4) Sending Bar-code transmission request command

STX 02	CR 0d	05	08	00	05	06	CR 0d
-----------	----------	----	----	----	----	----	----------

12	34	56	78	90	12	34	56
----	----	----	----	----	----	----	----

CR 0d	SUM ASC	CR 0d	EXT 03
----------	------------	----------	-----------

6. Details of Data Signal

(1) 3-D data transmission (Ver ID 03)

STX 02	CR 0d	05	06	00	04	03	CR 0d	Data1 lower
-----------	----------	----	----	----	----	----	----------	----------------

Command signal

Data1 upper	2-1 Diff.	3-2 Diff.	400-399 Diff.	CR 0d	Data1 lower	Data1 upper	2-1 Diff.
----------------	--------------	--------------	------------------	----------	----------------	----------------	--------------

Trace shape data 401 bytes

Trace curve data 401 bytes

3-2 Diff.	400-399 Diff.	CR 0d	Attached data	Attached data40	CR 0d	SUM
--------------	------------------	----------	------------------	--------------------	----------	-----

Attached data 40 bytes

CR 0d	EXT 03
----------	-----------

- a) Trace shape and trace curve data are 400-word data.
On transmission, transmit the lower and the upper of the top data, and then transmit the difference with the next data for the succeeding data.
- b) Attached data are composed of 20-word data and transmitted in the order of the lower, the upper, and byte on transmission.
- c) Trace shape data, trace curve data, and attached data, which are byte basis data, are converted into ASCII codes and transmitted from the lower after conversion.
e.g.: 1234H 34, 33, 32, and 31.
- d) Only the ASCII data for SUM is transmitted in the order of the upper and the lower after conversion.
- e) The following is an example to transmit the curve data "1000H, 1004H, and 1006H".
The order of transmission is 00H, 10H, (1004H-1000H), (1006H-1004H).
The actual transmission of the ASCII data will be as follows.
30 30 30 31 34 30 32 30
- f) The following is an example to transmit SUM data "56H".
The actual transmission of the ASCII data will be as follows.
35 36

(2) Both-eye data transmission (Ver ID 06)

STX 02	CR 0d	08	06	00	04	06	CR 0d
-----------	----------	----	----	----	----	----	----------

Command signal FD-80 (08) starts data transmission to AD800 (06) with Device (00) and version is 06 (06).

Data length lower	Data length upper	R Radius data1 lower (HEX)	R Radius data1 upper (HEX)	R Radius data2-1	R Radius data 3-2	R Radius data 400-399
-------------------	-------------------	----------------------------	----------------------------	------------------	-------------------	-------	-----------------------

Data length (HEX) is data byte number 1684=694HEX (94, 06 transmission)

R-trace shape data 401 bytes

R Top-Bottom data1 lower (HEX)	R Top-Bottom data1 upper (HEX)	R Top-Bottom data 2-1	R Top-Bottom data 3-2	R Top-Bottom data 400-399	L Radius data1 lower (HEX)	L Radius data1 upper (HEX)
--------------------------------	--------------------------------	-----------------------	-----------------------	-------	---------------------------	----------------------------	----------------------------

R-trace curve data 4-1 byte

L Radius data 2-1	L Radius data 3-2	L Radius data 4-3	L Radius data 5-4	L Radius data 400-399	L Top-Bottom data1 lower (HEX)	L Top-Bottom data1 upper (HEX)
-------------------	-------------------	-------------------	-------------------	-------	-----------------------	--------------------------------	--------------------------------

L-trace shape data 401 bytes

L Top-Bottom data 2-1	L Top-Bottom data 3-2	L Top-Bottom data 4-3	L Top-Bottom data 5-4	L Top-Bottom data 400-399	Attached data 1 lower	Attached data 1 upper
-----------------------	-----------------------	-----------------------	-----------------------	-------	---------------------------	-----------------------	-----------------------

L-trace curve data 401bytes

Attached data 80 bytes

Attached data2 lower	Attached data 40 upper	CR 0d	ASC SUM upper	ASC SUM lower	CR 0d	EXT 03
----------------------	-------	------------------------	----------	---------------	---------------	----------	-----------

For SUM data, total on the byte basis up to the previous data (CR) are transmitted after being converted to ASCII codes.

- a) Trace shape and trace curve data are 400-word data for each R and L.
On transmission, transmit the lower and the upper of the top data, and then transmit the difference (HEX) with the next data for the succeeding data.
- b) Attached data are composed of 40-word data and transmitted in the order of the lower, the upper, and byte in transmission. e.g.: 1234H 34, 12

- c) ASCII data for SUM is transmitted in the order of the upper and the lower after conversion.
- d) The following is an example to transmit the curve data "1000H, 1004H, and 1006H".
The order of transmission is 00H, 10H, (1004H-1000H), (1006H-1004H) (1005H-1006H).
The actual data transmission will be as follows.
00 10 04 02 FF
- e) The following is an example to transmit a SUM data "56H".
The actual transmission of the ASCII data will be as follows.
35 36

7. Details of Attached Data

(1) Terminology

【BOX】

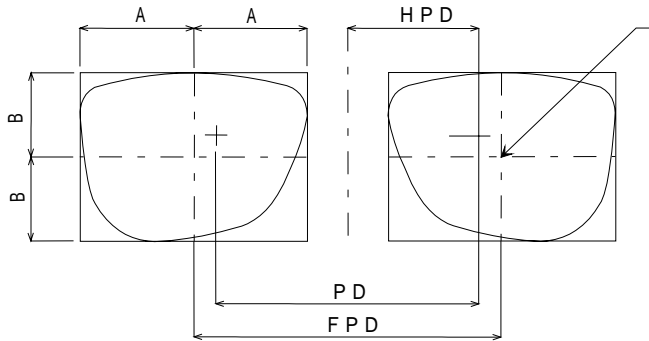

BOX center
(Communication data center)

【DTM】

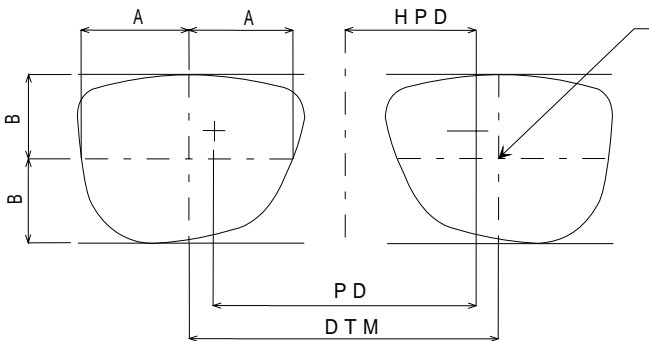

DTM center
(Communication data center)

【OPT】

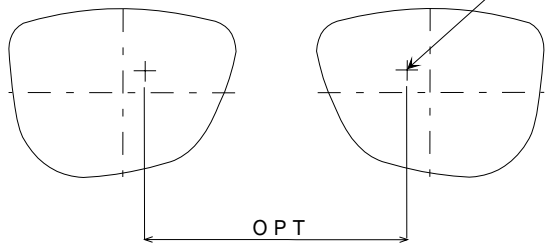

OPT center
(Communication data)

【VC,VB,VO】

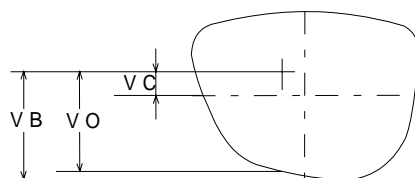

(2) Details of Ver ID 03 Attached Data (Data from PM-80)

Data Name		Data Length	Quantity	Contents, Supplementary explanation
Shape data		word	400	Geometrical center, Radius data
				1/100mm
Curve data		word	400	Lowest position=0
				1/100mm
Attached data	1	word	1	Frame scanner ROM version
	2	word	1	Diameter value: 1/100 Hexadecimal
	3	word	1	0=Frame tracing, 1=Lens tracing
	4	word	1	FPD value in BOX mode, PD value in OPT mode, DTM value in DTM mode, 1/10 Hexadecimal Distance between communication data centers
	5	word	1	VC value 500 is base (center). VO and VB values are distance from bottom 1/10
	6	word	1	PD=0, FPD=1, BOX=2, DTM=3, OPT in DTM mode=4
	7	word	1	Machine No.
	8	word	1	Machine No.
	9	word	1	Manual PD input value 1/10
	10	word	1	Types of horizontal line display VC=0, VB=1, VO=2
	11	word	1	FPD value is DTM value. 1/10
	12	word	1	PD=0, HPD=1
	13	word	1	Right-eye VC, VB, VO value 5000 is center for VC. 1/100 mm
	14	word	1	Left-eye VC, VB, Vo value 5000 is center for VC. 1/100 mm
	15	word	1	Right-eye HPD value 1/100mm
	16	word	1	Left-eye HPD value 1/100mm

(3) Details of Ver ID 06 Attached Data (Data from FD-80)

Data Name	Contents	Data Length	Quantity	Supplementary Explanation	Byte number
R shape data	R top geometrical center radius data	word	1	Accuracy: 1/100mm	401
	R geometrical difference data	byte	399	(add1+1)-add1 Accuracy: 1/100mm	
R curve data	R top curve data	word	1	Accuracy: 1/100mm	401
	Right curve difference data	byte	399	(add1+1)-add1 Accuracy: 1/100mm	
L shape data	L top geometrical center radius data	word	1	Accuracy: 1/100mm	401
	L geometrical difference data	byte	399	(add1+1)-add1 Accuracy: 1/100mm	
L curve data	L top curve data	word	1	Accuracy: 1/100mm	401
	Left curve difference data	byte	399	(add1+1)-add1 Accuracy: 1/100mm	
Attached data	FD-80 ROM version	word	1		2
	Machine No.	word	1		4
	Machine No.	word	1		6
	Communication data VER	byte	1	Starts with 01	7
	Measuring mode judge flag	byte	1	0=PD, 1=BOX, 2=OPT in DTM mode, 3=DTM	8
	Measuring object judge flag	byte	1	0=Frame, 1=Lens	9
	Horizontal line type judge flag	byte	1	0=VC, 1=VB, 2=VO	10
	Lens type judge flag	byte	1	0=Mono-focal, 1=Multi-focal, 2=Cylinder segment	11
	PD judge flag	byte	1	0=PD, 1=HPD	12
		byte	6		18
	R trace diameter value	word	1	Accuracy: 1/100 mm	20
	L trace diameter value	word	1	Accuracy: 1/100 mm	22
	FPD value	word	1	Accuracy: 1/100 mm	24
	L-HPD value	word	1	Accuracy: 1/100 mm	26
	PD input value (R-HPD value)	word	1	Sets to R-HPD value by PD judge flag. Accuracy: 1/100 mm	28
	Horizontal line display pos. value (R)	word	1	5000 is center in case of VC, and the value from the bottom in other modes. Accuracy: 1/100 mm	30
	Horizontal line display pos. value (L)	word	1		32
		word	3		38
	R BOX center X value	word	1	R OPT center is 5000, Distance up to BOX center, Distance inward is negative value. Accuracy: 1/100 mm	40
	R BOX center Y value	word	1	R OPT center is 5000, Distance up to BOX center, Distance upward from OPT center is positive value. Accuracy: 1/100 mm	42

Data Name	Contents	Data Length	Quantity	Supplementary Explanation	Byte number
Attached data	L BOX center X value	word	1	L OPT center is 5000, Distance up to BOX center, Distance inward is negative value. Accuracy: 1/100 mm	44
	L BOX center Y value	word	1	L OPT center is 5000, Distance up to BOX center, Distance upward from OPT center is positive value. Accuracy: 1/100 mm	46
	R eye point center X value	word	1	R BOX center is 5000, Distance up to eye point, Distance inward is negative value. Accuracy: 1/100 mm	48
	R eye point center Y value	word	1	R BOX center is 5000, Distance up to BOX center, Distance upward from BOX center is positive value. Accuracy: 1/100 mm	50
	L eye point center X value	word	1	L BOX center is 5000, Distance up to eye point, Distance inward is negative value. Accuracy: 1/100 mm	52
	L eye point center Y value	word	1	L BOX center is 5000, Distance up to BOX center, Distance upward from BOX center is positive value. Accuracy: 1/100 mm	54
		word	1		56
	R trace width	word	1	Accuracy: 1/100 mm	58
	R trace height	word	1	Accuracy: 1/100 mm	60
	R lens minimum diameter	word	1	Accuracy: 1/100 mm	62
	L trace width	word	1	Accuracy: 1/100 mm	64
	L trace height	word	1	Accuracy: 1/100 mm	66
	L lens minimum diameter	word	1	Accuracy: 1/100 mm	68
	Distance between Lenses (DBL)	word	1	Accuracy: 1/100 mm	70
	Spare 1	byte	1		71
	Spare 2	byte	1		72
	Bar-code 12	byte	1		73
	Bar-code 34	byte	1		74
	Bar-code 56	byte	1		75
	Bar-code 78	byte	1		76
Bar-code 90	byte	1		77	
Bar-code 12	byte	1		78	
Bar-code 34	byte	1		79	
Bar-code 56	byte	1		80	

Total bytes of RAM to be used are 1684 bytes.

8. Errors List

Machine Model	Display	Error Type	Contents
PM-80 Frame Scanner	Error 50	Communication error	Command signal checksum error
	Error 53	Communication error	Reception timeout error
	Error 52	Communication error	Not used.
	Error 51	Data error	Reception I.D. undefined error
LS-80 Lens Blocker	Error 11	Data error	No frame scanner data
	Error 12	Communication error	Communication signal checksum error
	Error 13	Data error	Frame scanner is OFF.
	Error 14	Communication error	Reception timeout error
	Error 15	Data error	Reception I.D. undefined error
AD-800 Automatic Edger	Error 21	Data error	Trace shape data is not smooth.
	Error 22	Data error	Communication opponent is OFF.
	Error 23	Data error	No trace shape data exists.
	Error 24	Communication error	EXT cannot be received.
	Error 25	Communication error	Command signal checksum error
	Error 26	Communication error	Data signal checksum error
	Error 27	Data error	Communication version mismatch error
	Error 28	Data error	Checkup model data
	Error 29	Data error	Trace shape data over 550 mm exists.
FD-80 Frame Tracer	Error 202	Communication error	Command signal checksum error
	Error 203	Communication error	Signal reception timeout error
	Error 204	Communication error	Signal timeout error (CPU)
	Error 205	Data error	Reception I.D. undefined error

